

## GENERAL GUIDELINES

Check pool component list and read the entire installation manual before starting. Use this installation manual, the installation video and the appropriate "dig spec" drawing supplied in your Pool Layout and Dig Dimensions Book.

## CONSTRUCTION SEQUENCE

1. Obtain all necessary permits.
2. Hire an electrician, if needed.
3. Arrange for water to be delivered, if needed (after liner is installed).
4. Arrange for fencing to be installed (check with building permit office for local codes).
5. Follow installation manual carefully and complete only the steps that pertain to the pool you are installing.

## TOOLS NEEDED FOR INSTALLATION

Adjustable Wrench  
Screw Drivers  
Socket Set  
25' and 50' Tape Measure  
Utility Knife  
Extension Cords  
String Line  
1/2" Drill and Bits  
Shovels (Flat & Round)  
Trowels (Mags & Finish)  
Carpenter's Square and Level  
Bobcat  
2 3/4" Hole Saw  
Hacksaw

Large Channel Lock Pliers  
Broom  
Tamper  
Sledge Hammer  
Hose  
Duct Tape  
Transit (Laser Level Preferred)  
Rakes  
Mighty Vac or Commercial Shop Vac  
Pick Axe  
Caulk Gun  
Backhoe (Qualified Operator)  
Marking Spray Paint (for marking ground)

## POOL LOCATION/LAYOUT

Choose pool location very carefully, as a less desirable site can increase your time and effort during installation. Consider the following when selecting a pool site:

1. Insure the pool is clear of all property lines and variances.
2. Insure a minimum 10' wide opening for access to the pool site by large equipment and concrete trucks.
3. Insure the pool site is clear of all underground pipes, tanks, wires and overhead wires.
4. Level ground is preferred, but not required. Water drainage away from all sides of the pool is necessary.
5. The pool site should be in a sunny area, with few, if any trees around the pool.
6. Try to position the long wall with the skimmer facing the prevailing winds.

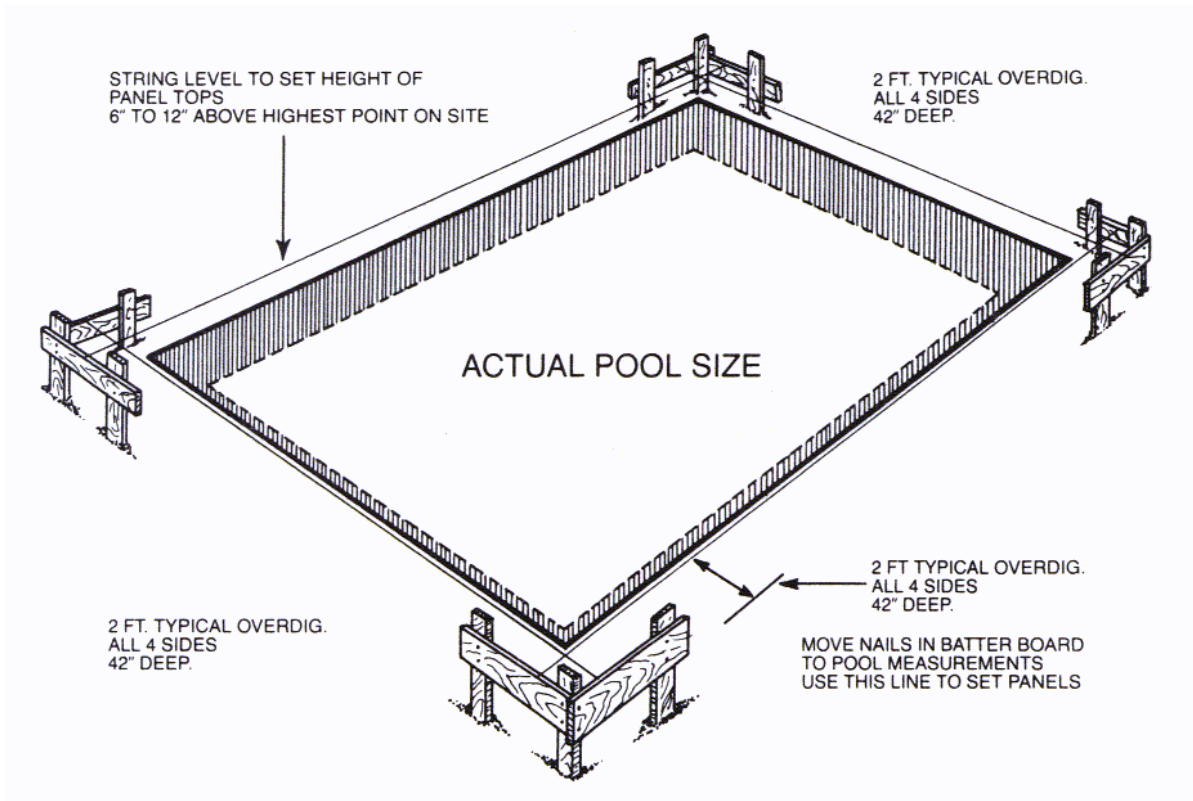

## INITIAL LAYOUT

### RECTANGLE:

All Rectangular pools have a two-foot overdig to form a shelf for the panels. Start by driving four stakes in the ground to make a box two feet larger than the pool you are installing. For example, a 20' x 40' pool requires a box that measures 24' x 44'. Square the box by measuring diagonally from stake to stake, ensuring all measurements are the same (see Figure 1).

### OVAL:

All oval pools have a two-foot overdig to form a shelf for the panels. Start by driving four stakes in the ground to make a box four feet wider than the pool but only as long as the straight wall. For example, an 18' x 36' pool requires a box that measures 22' x 18'. Square the box by measuring diagonally from stake to stake, ensuring all measurements are the same. To get the radius ends of the pool, locate the center point of the 22' width and drive a stake. Holding the end of a tape measure on the stake, move out 11' and paint an arc, connecting the ends of each straight side (see Figure 2).

### OCTAGON:

All Octagon pools have a two-foot overdig to form a shelf for the panels. Start by driving a stake at the center point of the pool. Holding the end of a tape measure on the stake, move out one half the width of the pool, plus two feet for the overdig, and paint a circle around the center stake. For example, a 24' octagon would require a circle 14' from the center stake.

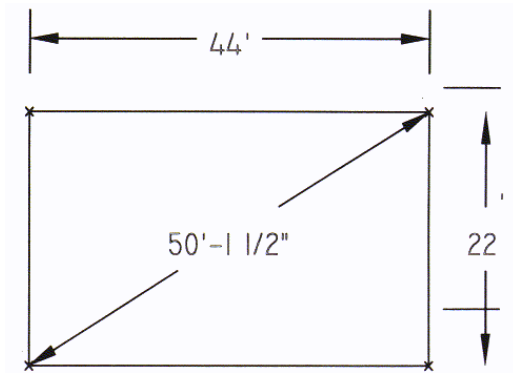

Figure 1 - Rectangle Pool Layout

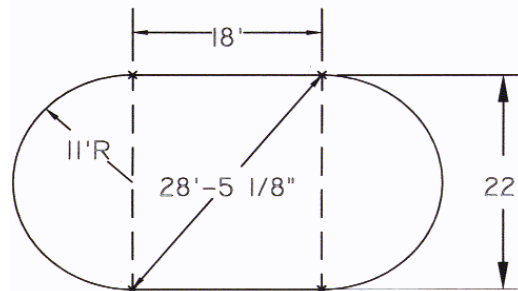

Figure 2 - Oval Pool Layout

## SETTING POOL ELEVATION

The top of the coping should be no less than 8" above the existing grade. 12" is suggested to keep all drainage away from the pool (see Figure 3). Now stretch a string line to each of your layout stakes at the level of the top of the pool (see Figure 4). If using a laser level, set proper benchmark.

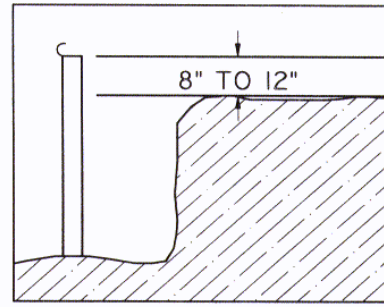

Figure 3 - Pool Elevation

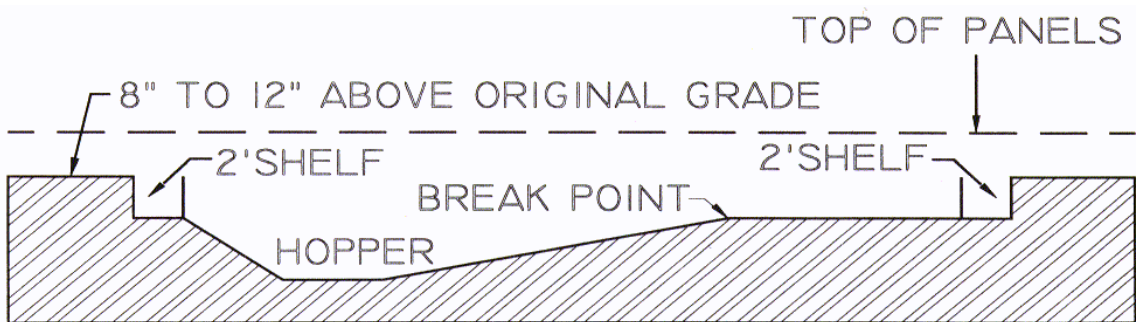

Figure 4 - String Level/Pool Layout

## EXCAVATION

All dimensions in the Pool Layout and Dig Dimension book are finish grades, so your excavation should always be 2" to 3" deeper than your Pool Layout and Dig Dimension drawing. This allows space inside the pool walls for mason sand or hard bottom materials.

## PANEL SHELF

Panels and braces will be assembled, set and leveled on the panel shelf (2' overdig). The shelf is dug 42" down from the string line or from your benchmark. This should be undisturbed earth so use caution when digging the shelf. **DO NOT OVERDIG!!!**

## SHALLOW END

Excavate the shallow end to 42" below the benchmark. If steps are to be installed, dig 2' wider than the step and 2' past your panel shelf (see Figure 5).

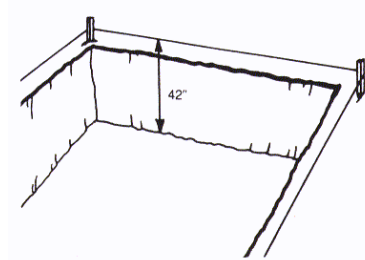

Figure 5 - Shallow End

## DEEP END

Once the shallow end is dug, paint a line across the pool to represent the break line. To understand the shape of the deep end on a standard hopper pool, envision the hopper as an upside down pyramid, whose top has been cut off (see Figure 6). To achieve this shape, start by dividing the length of the slope by four and marking four equal sections on the wall of the overdig. For example, a 14'

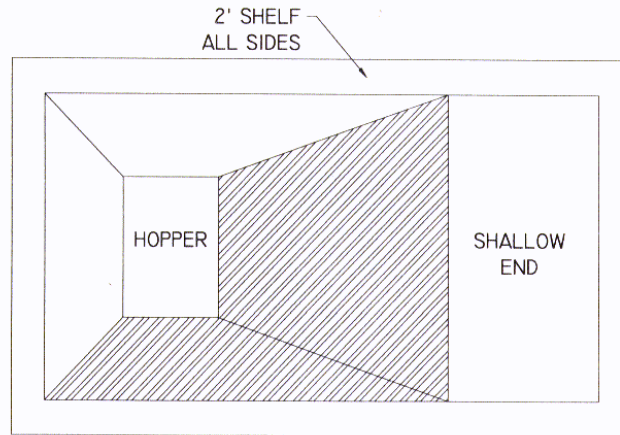

Figure 6 - Hopper Dig

For example, a 14' slope would have four sections, 3'6" each. Then divide the wall height by four and mark the side and back wall into four equal sections. For example, a 4' sidewall would have four 1' sections. Now start excavating the hopper at the break line. As the dig proceeds down the slope, use the marks you have made as boundaries for the dig. For each mark you pass on the slope, move your dig boundary in and down one mark on the sidewall. Using our earlier example, as the dig moves 3'6" down the slope, the dig boundary on each side would move in 1' from each sidewall toward the center of the pool, and 1' deeper. The backhoe operator should continue this process, tapering all sides, until the end of the slope is reached. Now, continue with the same dig boundary for the length of the hopper. The back wall should be tapered to the same slope as the sidewalls at the hopper. Caution your operator to work slowly and accurately, and monitor the digging process closely. **DO NOT OVERDIG OR UNDERDIG.**

## GROUND WATER CONDITIONS

Ground water is the term used for the water table. If you should encounter ground water while digging the hopper, don't panic - just follow these simple recommendations:

1. Overdig just the bottom of the hopper by 1' to 2'.
2. Use pea size rock to bring the hopper back to grade.
3. Set a foot valve in the pea stone and plumb it to the outside of the pool.
4. Run a plumbing line from the hopper to near the filter (see Figure 7).
5. Hook the foot valve to a pump and keep the pump running continuously until the liner has been dropped and the pool is full of water.
6. When installation is complete, cap the plumbing line, leaving it available for use in the future, should the liner need to be replaced.

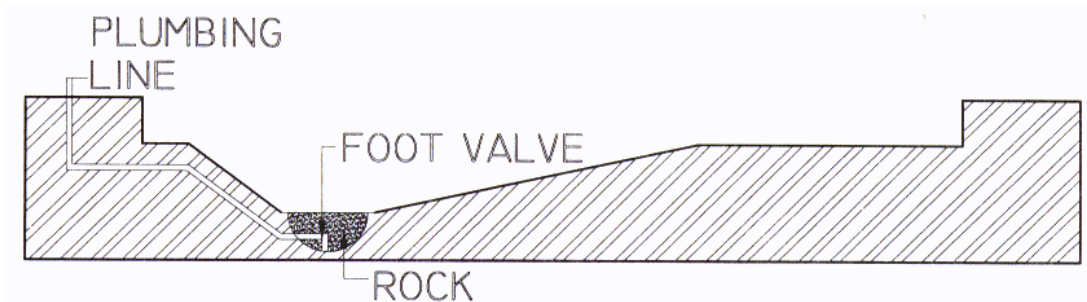

Figure 7 - Ground Water Solution

## PANEL INSTALLATION

Start by laying out all panels on the panel shelf. Position a brace and 4 bolts at every panel joint, as indicated in the Pool Layout and Dig Dimension Book.

Starting in the appropriate place for the shape of the pool being built (see below), fasten panels and braces together, using non-corrosive bolts. Align the panel joints for a tight fit and hand-tighten the non-corrosive bolts - **DO NOT OVERTIGHTEN!!!**

Panels are available with pre-cut holes for most commonly used skimmers. Position the skimmer panel according to the following guidelines:

1. The skimmer should always be placed on the long wall of the pool, with the prevailing winds blowing into the skimmer.
2. If you are building a hopper pool, locate the skimmer in the deep end of the pool, past the break point.
3. Insure the skimmer panel will be clear of the wall-mounted safety rope anchors.
4. Locate returns on walls opposite the skimmer, to push surface debris towards the skimmer.

## STARTING POINT - RECTANGULAR POOLS

Begin in a shallow end corner. In 4' radius pools, start by bolting the two corner panels together, with a brace between them, then connect the corner panel assembly to an end-wall straight panel, with a brace between them (see Figure 8). In 6" radius pools, bolt the corner panel directly to an end-wall straight panel, with a brace between them. Continue to assemble panels and braces according to the Pool Layout and Dig Dimension Drawing. If steps are present, determine their location before starting panel assembly and complete the step installation process (see next page) when you reach their position.

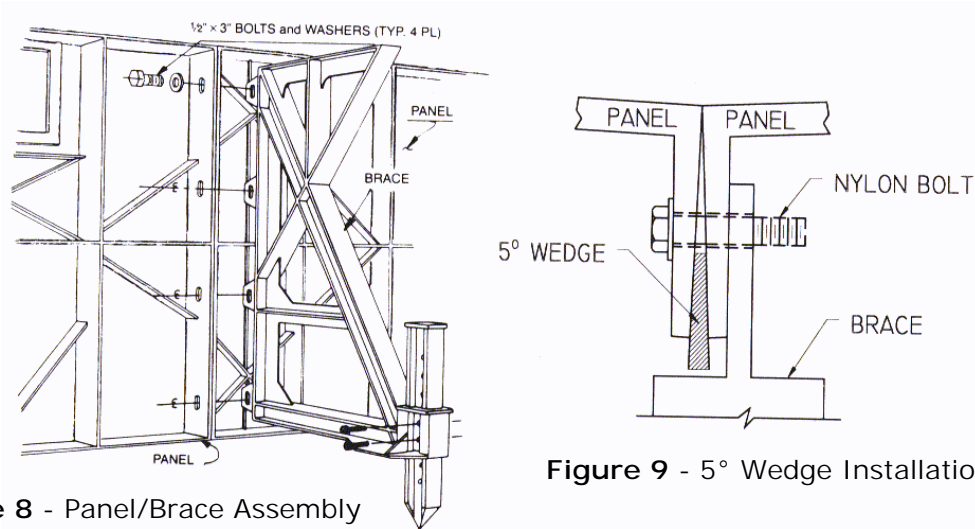

Figure 8 - Panel/Brace Assembly

Figure 9 - 5° Wedge Installation

## STARTING POINT - OVAL POOLS

Begin at a straight sidewall and bolt the straight panels and braces together. Repeat this process for the other straight sidewall. Square both sidewalls by measuring diagonally across the pool at both the top and the bottom of the panels. Drive stakes a few inches into the ground at the ends of the straight sections to hold them in place. Begin to assemble the radius ends. Bolt the first curved panel and brace to the end of a straight sidewall. If required, use 5° wedges (see Figure 9) to adjust the radius, as indicated in the Pool Layout and Dig Dimension Drawing. Continue to assemble panels and braces according to the Pool Layout and Dig Dimension Drawing. If steps are present, determine their location before starting panel assembly and complete the step installation process (see next page) when you reach their position. Insure the radius is true by driving a stake halfway between the sidewalls, stretching a tape measure from the stake to the radius panels, and checking the distance at various points on the curve. All measurements should be the same. If not, slightly shift the curved panels until a constant radius is achieved.

## HYDRA STEP AND SWIM OUT INSTALLATION

In all HYDRA pools, steps and swim outs are installed in the same manner. Start by setting the step in the excavated area according to the Pool Layout and Dig Dimension Drawing. Follow the step manufacturer's suggestions for supporting the step. With the step in place, clamp the neighboring pool panel to the step, insuring that the face of the step is flush with the panel and that the top of the panel is flush with the bottom of the step coping-receptor nose.

With the panel and step clamped tightly together, drill 3/8" holes through the panel holes into the step flange. Use stainless steel bolts to secure the panels/braces to the step.

## INSTALLING ALUMINUM COPING

Two types of coping are provided with your HYDRA pool - straight and pre-shaped. Start by installing all pre-shaped coping. This includes 6", 4', and 9 radius, Roman End, 45°, Lazy-Ell and True-Ell. Start by positioning the pre-shaped coping on the appropriate panels insuring that the coping lip fits snugly against the face of the panel. Using the self-tapping screws provided, secure the pre-shaped coping to the panels, starting at the ends of each piece of coping, and every 12" along the length of the coping. Next, install the

straight coping onto the panels, leaving a 3/8" gap between pieces for expansion. Secure the straight coping to the panels, using the self-tapping screws provided. When installing the straight coping, insure that the coping joints do not line up with any of the panel joints, except at the junction of straight and pre-shaped coping. Finally, snap the coping clips over all coping joints.

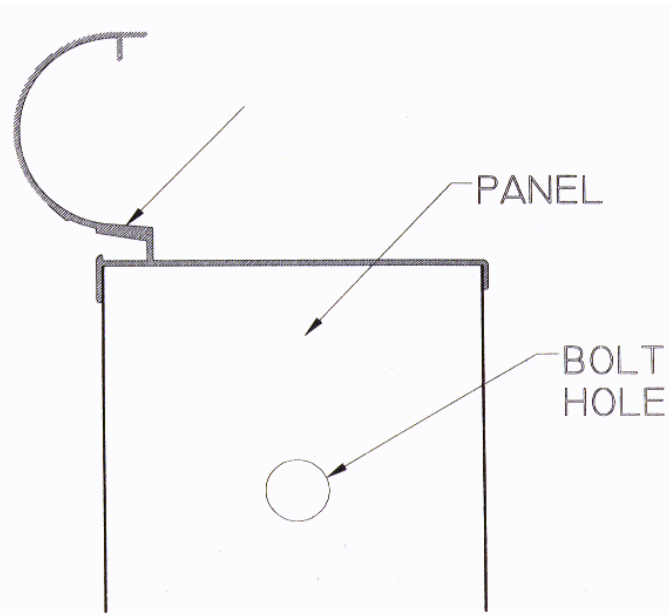

Figure 10 - Coping Installation

## FINAL CHECK - ALL POOLS

Once all panels, braces and steps have been bolted together and the coping has been secured to the panels, it is time for one final check. A few extra minutes spent verifying the shape of the pool at this stage of completion will lead to a proper liner fit, and ultimately, a satisfied homeowner.

1. Check diagonal measurements across the pool, at both the top and bottom of the panels, and verify that they are the same.
2. Level all panels, using patio blocks or bricks at the panel joints, so that the top of the panel is level with the benchmark set at the start of construction.
3. Check all panels for vertical alignment, using a carpenter's level on the face of the panel.
4. Check all straight walls for horizontal alignment. To do this, stretch a string the entire length of each straight wall, at the bottom of the panels, insuring that each panel lines up with the string.

## STAKE AND SECURE THE POOL

At this point, the panels are ready to be secured to the ground. First, use a hacksaw to detach the polymer stakes from the braces. Place stakes in the channels at the back of the brace and drive into the ground, using a sledge hammer. SAFETY GLASSES MUST BE WORN WHEN DRIVING STAKES! Leave 1" of the stake visible above the top of the stake channel. Snap the locking pin off the brace and use it to secure the brace to the stake. Next, drive 3/8" rebar through the pre-drilled holes in the bottom of each panel. This keeps the bottom of the panels from shifting when pouring the concrete collar. Use 24" pieces of rebar, driven 18" into the ground. Finally, brace the step. Use 3/8" rebar and a 2" x 6" wooden plank, as shown in Figure 11.

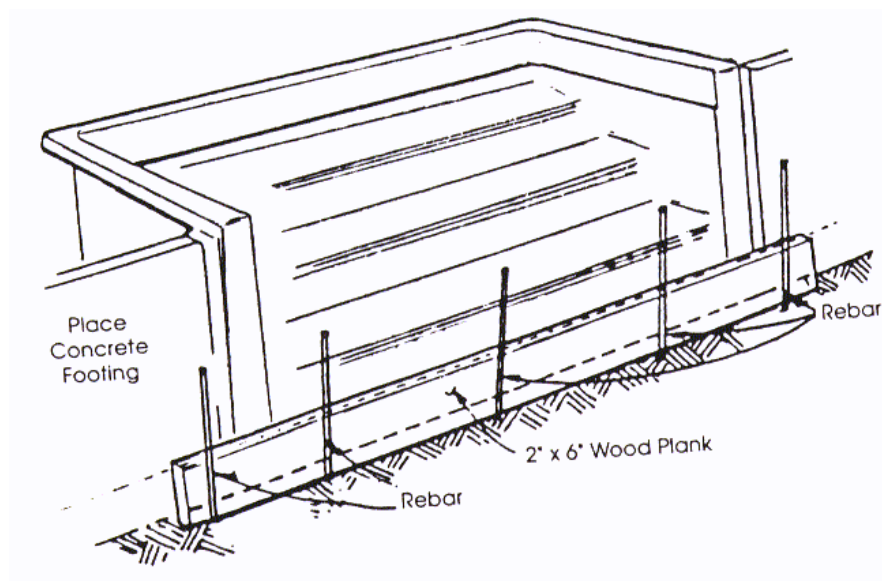

Figure 11 - Step Bracing

## PLUMBING

### MAIN DRAIN MUST BE DONE BEFORE BOND BEAM IS INSTALLED.

Dig a hold in the center of the hopper, 1' in diameter and 18" deep. Partially fill the hole with approximately 14" of rock. When the main drain is correctly positioned in the hole, the top of the drain should be at the finish grade, and there should be 4" to 6" of the drain exposed above the rock. The remainder of the hold must be filled with concrete to secure the drain in place. MAIN DRAIN MUST BE SET IN CONCRETE. To install your plumbing line, dig a small trench in the hopper, starting at the main drain, crossing the hopper, up the side or back wall slope (whichever is closest to the filter), and out under a panel. Set your line, cover with dirt and tamp. Leave main drain faceplate and gaskets off until the liner is installed.

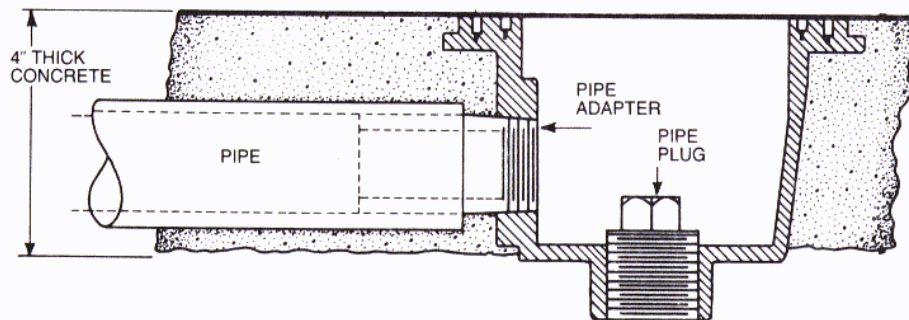

Figure 12 - Main Drain Installation

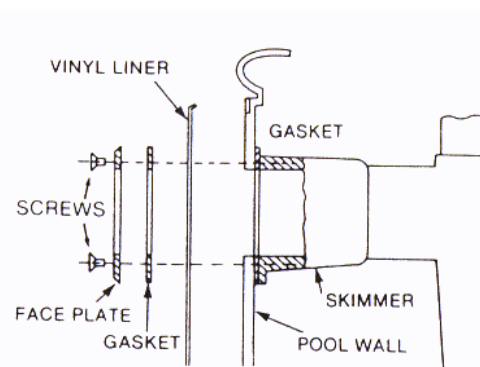

Figure 13 - Skimmer Installation

### SKIMMER

The skimmer panel is pre-cut for your convenience. Simply slip your skimmer through the cutout (see Figure 13), install the shim kit and fasten the skimmer to the wall panel, following the manufacturer's instructions. Using this method of installation, gaskets are NOT required until liner installation. **DO NOT CUT THE LINER UNTIL WATER IS AT LEAST 12" DEEP IN THE SHALLOW END OF THE POOL.**

## RETURN FITTINGS

Return fittings can be located on any wall, as long as they produce a circular flow pattern on the surface of the water, toward the skimmer. Drill a 2 3/4" hole in the panel, 12" to 14" down from top of panel, NOT the top of coping. Slide the return fittings through the hole from the inside of the panel and install the lock nut - tighten snugly. Leave the fitting faceplate off until liner has been installed and the water is at least 12" deep in the shallow end of the pool.

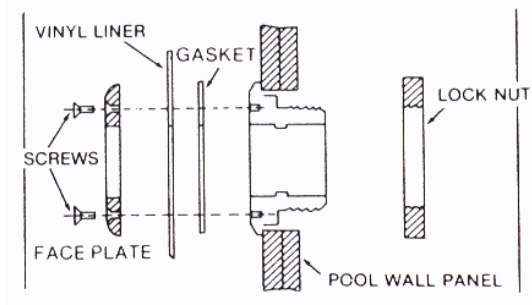

Figure 14 - Return Installation

## LINES

Now you are ready to run all plumbing lines to the filter location. Refer to the Plumbing Schematic inside the back cover.

## **CONCRETE BOND BEAM (COLLAR)**

When the plumbing lines are run, you are ready to pour the concrete collar around the pool. Insure there are no gaps under the panels or step - if there are, tamp dirt to fill the opening. Now, stretch a string line down the length of each of the straight walls at the back edge of the coping and insure all panels are flush with the string. Now, begin pouring your concrete collar. The concrete should be poured 8" to 10" thick, with a slight slope away from the panel for drainage, and the width of the overdig. **CHECK WITH YOUR LOCAL BUILDING/ZONING OFFICE FOR APPLICABLE CODES.** Pour concrete SLOWLY to prevent forcing the walls out of alignment. After the concrete is poured, recheck all panels for proper panel alignment, using a string. When pouring concrete under the step, insure that the concrete touches the underside of the first tread for proper support.

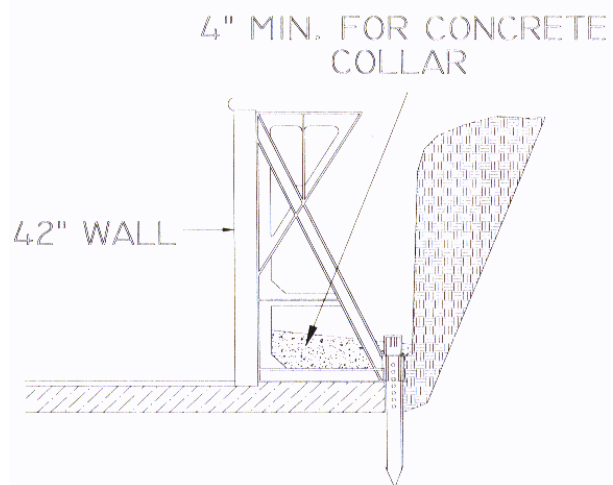
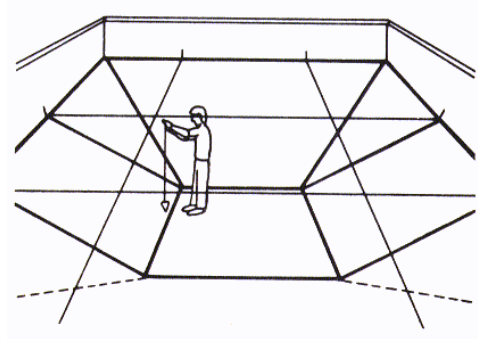
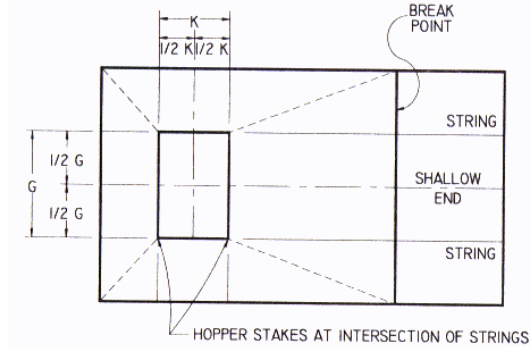

Figure 15 - Concrete Collar

## GRADING THE POOL BOTTOM FOR SAND AND CEMENT

The pool must be graded 2" below the finish dimensions in the Panel Layout and Dig Dimension Drawing. This will be finished with a 2" layer of mason sand and cement or a suitable pool base material.



Locate the sides of the hopper pad by stretching parallel strings from the breakover point to the end wall. At the same time, locate the front and back of the hopper pad by stretching strings between the sidewalls of the pool.

Find the finish grade by dropping a plumb bob at the intersection of the strings to the depth shown on your Dig Dimension Drawing. Drive a stake into each corner of the hopper beneath the plumb line and string a level line between stakes at the required depth to indicate the exact position and finish grade of the hopper.

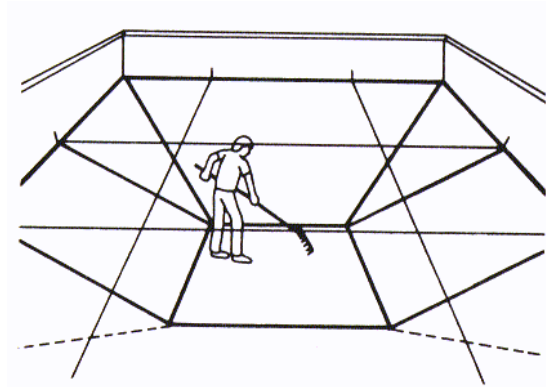

Once you have located the hopper pad, use stakes and strings in the same manner to mark the finish grade of the hopper walls, as shown on your Dig Dimension Drawing.

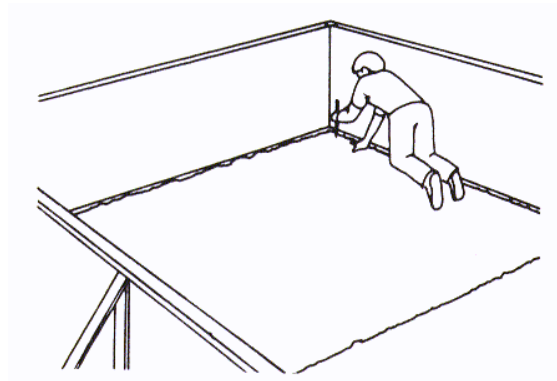

In each corner of the shallow end, measure the required depth from the top of the panels to the pool bottom and place a marker. String a level line between markers to indicate the finish grade of the bottom.

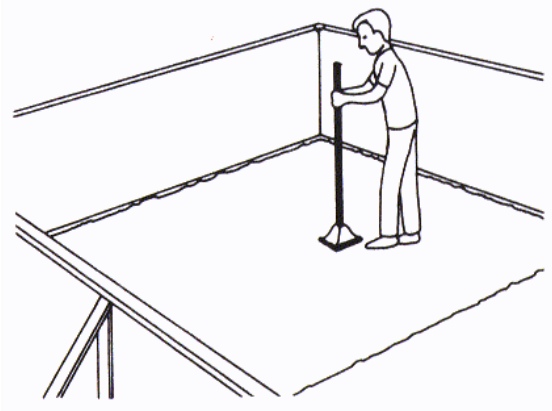

When finish grade has been established, remove at least 2" of earth from below the strings. Tamp the entire area thoroughly and take away all stones, twigs and rocks.

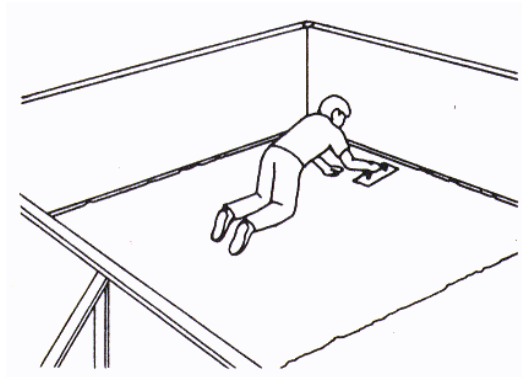

Starting in the hopper end, bring the pool bottom up to finish grade with a damp sand/concrete mixture. Trowel smooth and broom lightly to remove trowel marks.

## PLACEMENT OF SAND/CEMENT MIXTURE

To save effort when adding the sand/cement mixture, dump it near the area to be troweled. A certain amount will roll down. The balance will be easy to rake down. Particular care should be taken with the troweling of the sand/cement bottom. The smoothness and evenness of the bottom will determine the appearance of the liner when it is placed in the pool.

In order to get maximum compaction and surface smoothness, thoroughly-washed, mason sand should be mixed with cement in a 7-1 (sand to cement) ratio. This will allow the finishing operation to proceed smoothly.

**Note:** If optional Vermiculite is used, mix 2 bags Vermiculite to 1 bag gray (94lb.) cement, or use pre-mixed aggregate.

# VINYL LINER INSTALLATION

## GENERAL INFORMATION

Vinyl liners should be stored in areas with temperature above 50°F to prevent excessive shrinkage and permanent folds in the vinyl.

## COLD WEATHER INSTALLATION

When installing a liner in temperatures of 65°F or lower, store liner at 70°F to 80°F for at least 72 hours prior to installation. When the bottom is finished, bring out the liner and drop it as quickly as possible. Try to drop the liner in direct sunlight to help seat the liner properly. Do not leave a boxed liner exposed to the elements.

## TOOLS NEEDED FOR LINER INSTALLATION

Commercial vacuum(s) (Might Vac recommended)  
Screw Drivers, Phillips and Straight  
Razor Knife

Garden Hose  
Broom  
Two to Four People

## LINER INSTALLATION

Vinyl liner installation can be fast and easy - just follow these guidelines!

1. Before you begin installing the liner, insure that the pool bottom is free of any stones, sticks and footprints.
2. Use duct tape to tape all panel joints. **DO NOT USE CAULK!**
3. Use caulk to secure gaskets to the main drain and skimmer.
4. Insure liner track is clean and free of any sand, concrete, etc.
5. If steps are used, refer to the next section before continuing with liner installation.
6. Remove the liner from the box. Place the liner in the deep end of the pool, with arrows facing the shallow end. Carefully unfold the liner. Have two people take the shallow end corners and pull the liner to the shallow end (see Figure 22), keeping the liner away from any sharp edges. **AVOID DRAGGING THE LINER ACROSS THE SAND BOTTOM.**

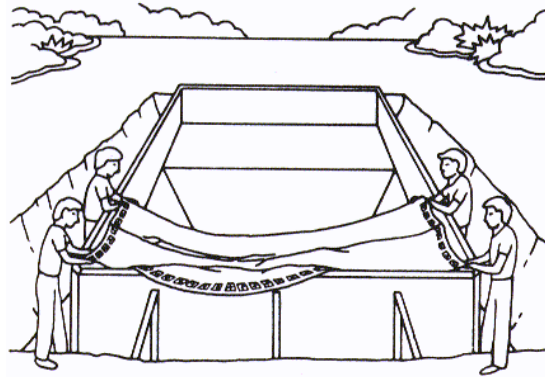

Figure 22 - Liner Unfolding

7. From the outside of the pool, snap liner bead into the liner track in each shallow end corner (see Figure 23). Continue snapping the bead into the track across the shallow end of the pool. Now, start down the long sides, toward the deep end. Several feet past the breakline, stop and square the liner over the breakline, using the seam as a guide. When the liner is square, continue snapping the bead into the track, being careful not to overstretch the liner. Push the liner bead into the liner track completely to insure proper locking.

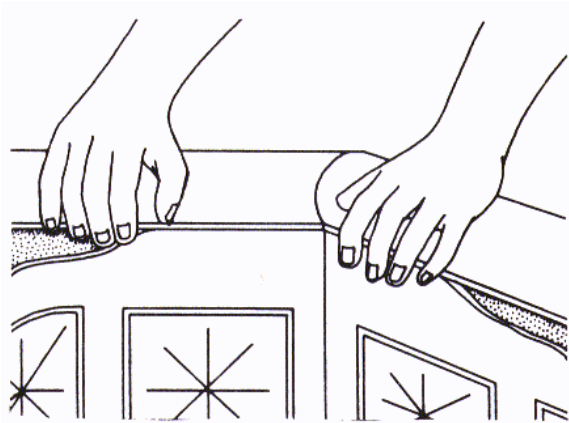

Figure 23 - Liner Bead Installation

8. After the liner bead is completely installed in liner track, adjust the liner in the pool corners, as required, to achieve a smooth, loose fit in the corners. Do not stretch the liner tightly over inside corners.
9. When the liner is positioned correctly, remove a small area of the liner bead from the liner track close to the breakpoint and insert approximately 36" of vacuum hose behind the liner. **DO NOT ALLOW VACUUM HOSE TO TOUCH THE POOL BASE!** Use duct tape to tape the hose in place and seal the opening around the hose to create a vacuum behind the liner. **NOTE:** Larger pools may require two vacuums.
10. Turn on vacuum(s). As suction starts to pull the liner down, continually adjust the fit by pulling the excess material on the floor toward the base of the pool walls. If you can't get all wrinkles out, shut off the vacuum(s), reposition the liner in the pool, turn the vacuum(s) back on and start the process again.
11. When the liner is pulled down snugly, with no wrinkles, you are ready to finish installing the main drain. By feel, locate the screw holes in the top of the main drain, under the liner. With the gasket in place, screw the faceplate to the main drain, following the manufacturer's instructions. **CAREFULLY**, use a razor knife to cut out the liner material **INSIDE** the main drain frame and install the main drain cover.
12. Using a standard garden hose, place the hose end in the hopper and start water flow. Once there is 6" of water in the hopper, the remainder of the pool can be filled from the garden hose or a water truck. **DO NOT ALLOW A STRONG STREAM OF WATER TO DIRECTLY HIT THE POOL BOTTOM.**

13. When the water is 6" deep in the shallow end, remove the vacuum(s) and replace the liner bead in the liner track. If steps are used, install the step gaskets and faceplate now (see Figure 24).
14. When the water is at least 12" deep in the shallow end, locate the returns and the skimmer(s). Install the gaskets/faceplates, following the manufacturer's instructions. **CAREFULLY**, use a razor knife to cut out the liner material **INSIDE** the returns and skimmer(s).
15. DO NOT REMOVE THE VACUUM(S) WITH LESS THAN 6" OF WATER IN THE SHALLOW END AND DO NOT ALLOW THE VACUUM(S) TO RUN WITH MORE THAN 12" OF WATER IN THE SHALLOW END. IF THE VACUUM(S) ARE SHUT OFF FOR ANY REASON BEFORE THE WATER IS 6" DEEP IN THE SHALLOW END, THE WATER MUST ALSO BE SHUT OFF UNTIL THE VACUUM IS RESTORED.

## HYDRA STEP AND SWIM OUT LINER INSTALLATION

Using a thin piece of plywood, cover the top of the step section. Mount a piece of coping to the wood so that the liner will maintain a straight profile over the step. Use duct tape to seal the wood over the steps and seal all openings around the liner. When the water is 6" deep in the shallow end, install step gaskets and faceplates, using stainless steel screws and following the manufacturer's instructions. **CAREFULLY**, use a razor knife to cut out the liner material **INSIDE** the step faceplates. Install screw covers, following manufacturer's instructions.

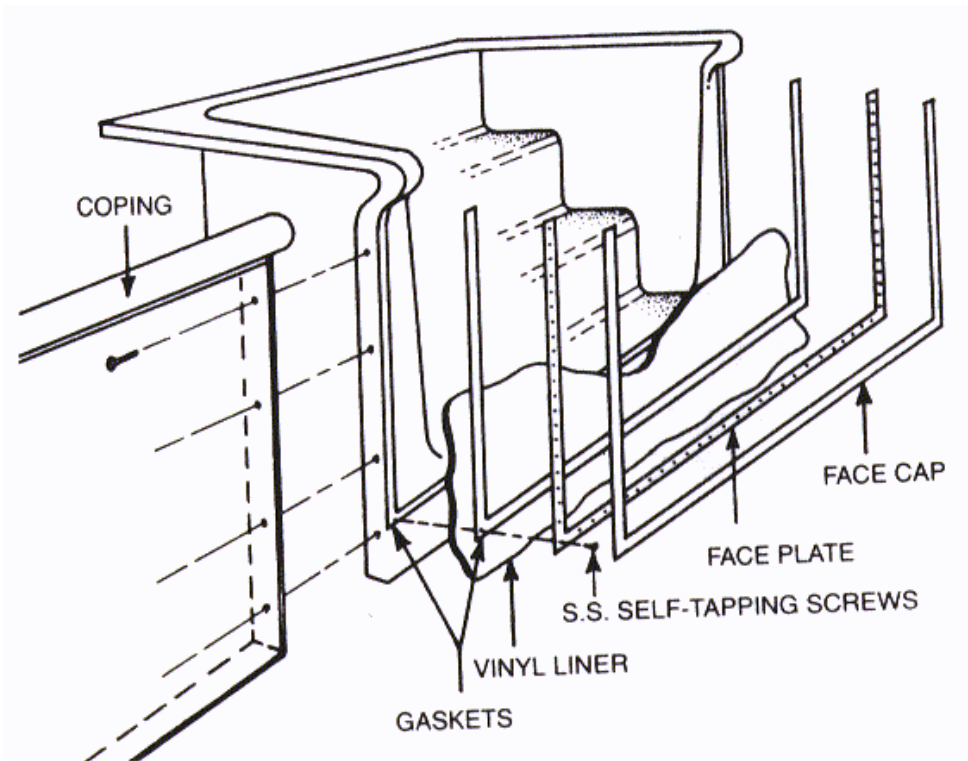

Figure 24 - Step Faceplate Installation

## BACKFILLING YOUR HYDRA POOL

There are several methods used in backfilling the pool. One method is to backfill as the pool is being filled with water, keeping the water level even with the backfill material. The backfill material should be placed in layers and kept even all around the pool. **USE ONLY NON-EXPANSIVE MATERIALS FOR BACKFILL. DO NOT USE COHESIVE (CLAY) MATERIALS.** EXCAVATED materials can be used in low ground frost areas. Bring the backfill grade to within 1/2" of the top of the braces, leaving the brace top exposed.

Another method of backfilling is used when pouring the deck, prior to filling the pool with water. Pool walls **MUST** be braced to avoid panel movement during backfilling and pouring deck. Follow guidelines above.

## INSTALLING CONCRETE DECK

1. Insure tops of the braces are exposed so the concrete can bond to the brace.
2. Insure the coping clips are installed over the coping joints. Use duct tape to completely cover the face of all coping, to protect it from splashing concrete.
3. Concrete should be reinforced with either wire mesh or a fiber mesh additive (available from most concrete companies).
4. Concrete should be a minimum of 6" thick at the pool edge and taper down to 3 1/2" on the outer edge.
5. For proper drainage, the must slope 1/4" for every 1' of width.
6. Install ladder/handrail anchors, as required, when forming deck. Follow manufacturer's instructions.
7. Insure concrete completely fills the coping.
8. Insure concrete completely fills the gap under the lip of the step to provide additional structural support.
9. Broom finish the concrete for a non-slip surface or apply other concrete toppings, such as cool deck.
10. Edge and groove expansion joints or use expansion joint material. Do not position expansion joints directly over the pool wall braces.
11. Use additional support (piers) down to undisturbed earth when deck extends more than 4' from the pool wall.
12. Pour the deck at least 8' wide where diving board is installed.

## SAFETY ROPE

Use the National Spa and Pool Institute Guidelines to determine the correct position for the safety rope. Install coping-mounted rope eyes in this position and fasten the safety rope, following the manufacturer's instructions.

# DETAIL DRAWINGS

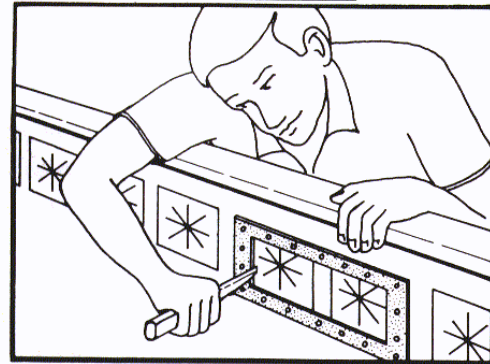
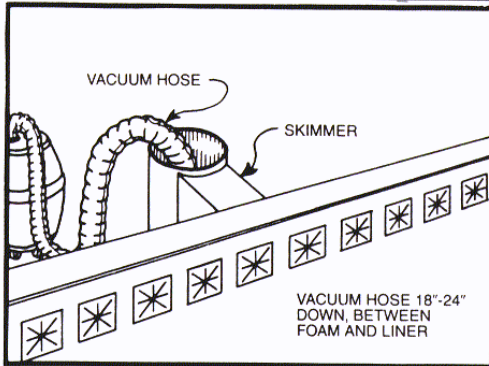
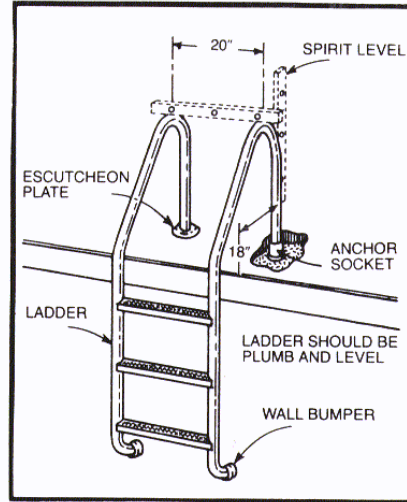
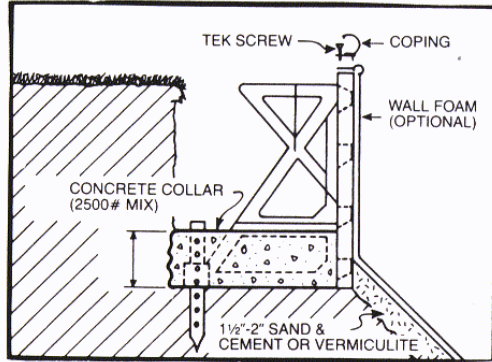

As soon as the liner is pulled into place, start filling the pool. Leave vacuum on until water is 6" deep in the shallow end.

When water level is 2 feet above panel bottoms screw skimmer, returns and light face plates with gaskets to wall fittings. Using a knife carefully cut out vinyl from inside face plates.

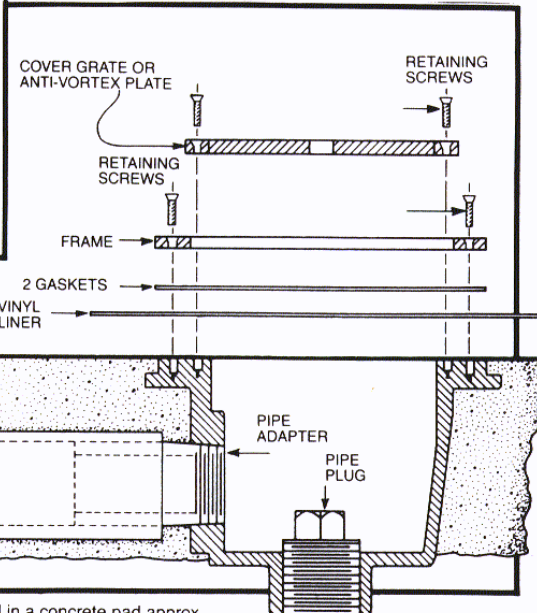
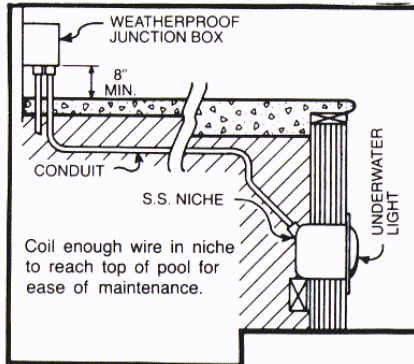

The main drain should be mounted in a concrete pad approx. 24" x 24" x 4" thick. The piping from the main drain should be installed and run out from pool area before pouring concrete bond beam around pool.

# POOL PLUMBING SCHEMATIC

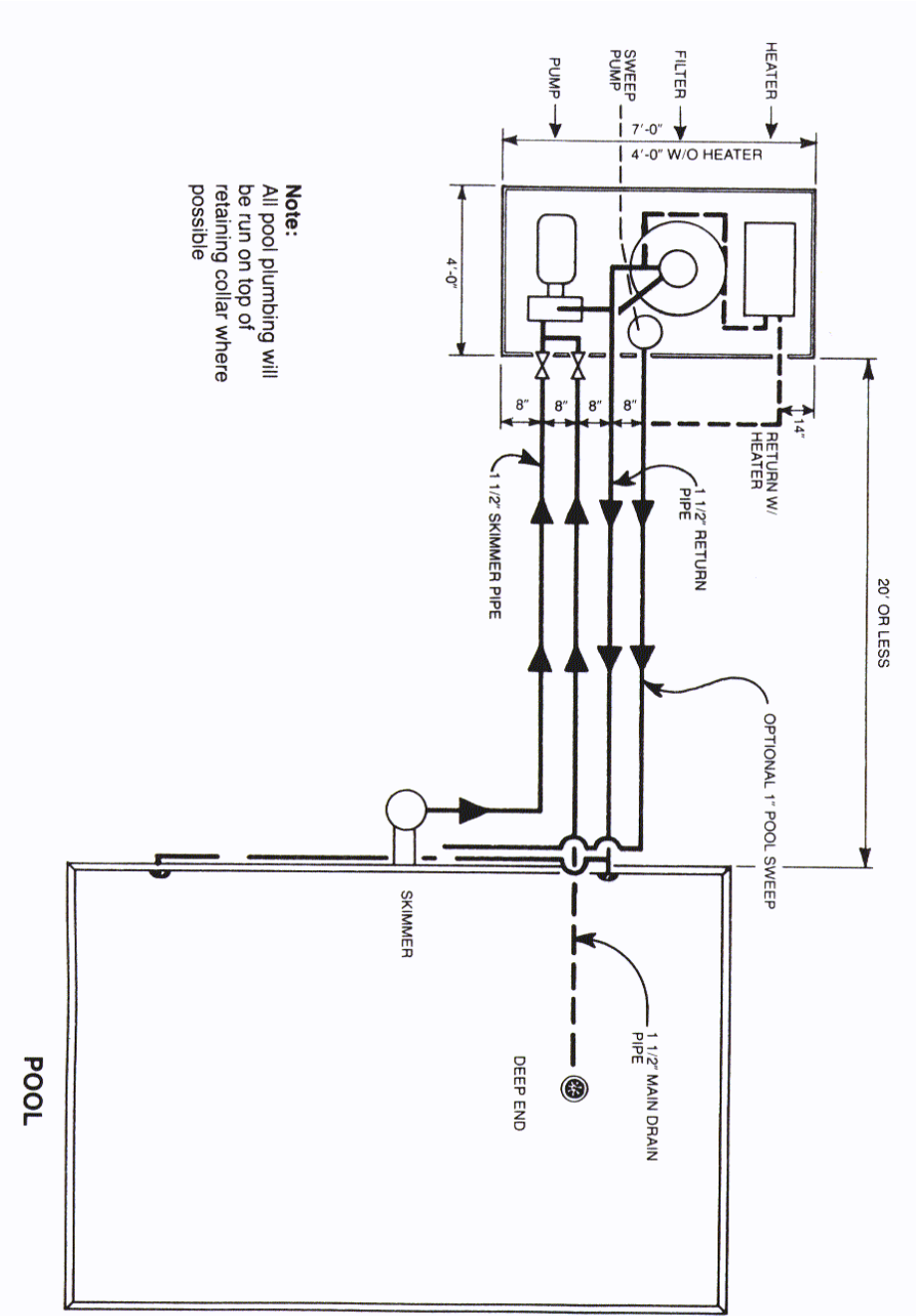

**Note:**  
 All pool plumbing will be run on top of retaining collar where possible

NOTES: